

**emco** group

Designed for your profit

[ E[M]CONOMY  
means: ]



## Productivity in perfection. HYPERTURN 65

High-performance turn/mill center with up to 3 tool turrets  
for even greater flexibility and productivity.

# HYPERTURN 65 DUOTURN

## [ Tool system 1 / 2 ]

- 12-station tool turret
- VDI30 (VDI40) quick-change system
- 12 driven tool stations
- Servo-controlled
- Rigid tapping
- Polygonal turning, etc.

## [ Main spindle ]

- Integrated, water-cooled spindle motor
- Spindle nose KK6 (KK8)
- High drive power 29 kW
- High torque 250 Nm
- Large speed range 0 – 5000 rpm
- Bar capacity diameter 65 (76.2) mm

## [ Control unit ]

- Ergonomic control panel
- Pivotal and extendible
- Sinumerik 840D-sl with HMI-OPERATE
- Comprehensive machining cycles
- 3D simulation
- USB interface

## [ Multi-function unit ]

- 220V power socket
- Air connection
- Network connection RJ45



Machine with optional equipment

The HYPERTURN 65 is a new development in the HYPERTURN range. Its smart modular design means it perfectly meets specific customer requirements. Two identical high-performance spindles set the basis for unlimited machining. Two, or even three, turrets on the cross slide with optional Y-axis to ensure greater productivity. Each position on the tool turret can accommodate both stationary and driven milling/drilling heads.

# [Workpieces]

## [Y-axes 1 / 2 ]

- Travel +/- 50 mm
- Stable, compact construction
- Largely spaced guide ways
- Wedge-style design

## [Counter spindle]

- Integrated, water-cooled spindle motor
- KK6 spindle nose
- High drive power 29 kW
- High torque 250 Nm
- Large speed range 0 – 5000 rpm
- Incl. coolant-fed parts ejector
- Optional with Ø 65 mm through hole for shaft unloading

## [Chip conveyor]

- Hinged type conveyor belt
- Ejection height 1200 mm
- Integrated coolant tank 350 l
- Turret pumps: 3 x 14 bar
- Flushing pumps: 2 x 3.7 bar

## [Work area]

- Large spindle distance 1300 mm
- Optimum accessibility
- Straight chip drop
- Stainless steel covers and linings
- Tailstock/steady rest function on lower turret

## [Finished parts container]

- Easy access
- Universal
- Extendable with finished part conveyor

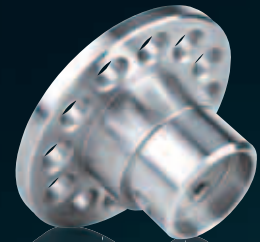

Eccentric flange  
(42 Cr Mo 4 Steel)



Adapter  
(Ck 45 Steel)

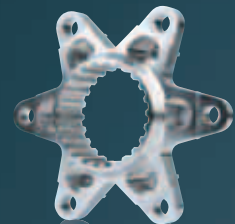

Sprocket adapter  
(Aluminium 7075)



Tappet  
(Steel 16 Mn Cr 5)

# HYPERTURN 65 TRIPLETURN

## [ Tool system 1 / 2 / 3 ]

- 12-station tool turret
- VDI30 (VDI40) quick-change system
- 12 driven tool stations
- Servo-controlled
- Rigid tapping
- Polygonal turning, etc.

## [ Main spindle ]

- Integrated, water-cooled spindle motor
- A2-6 (A2-8) spindle nose
- High drive power 29 kW
- High torque 250 Nm
- Large speed range 0 – 5000 rpm
- Bar capacity diameter 65 (76.2) mm

## [ Control unit ]

- Ergonomic control panel
- Pivotal and extendible
- Sinumerik 840D-sl with HMI-OPERATE
- Comprehensive machining cycles
- 3D simulation
- USB interface

## [ Multi-function unit ]

- 220V power socket
- Air connection
- Network connection RJ45



Machine with optional equipment

The HYPERTURN 65 Triple Turn is a new member of the Hyperturn family designed to bring even greater productivity gains. In addition to the two top-mounted tool turrets, the ace in the pack is an extra 12-station turret which enables greater productivity and increased flexibility when machining complex workpieces in one clamping cycle. This means that three tools are generally in use simultaneously, which reduces part production time by up to 30%.

# [Workpieces]

## [Y-axes 1 / 2 / 3]

- Travel +/- 50 mm
- Stable, compact construction
- Largely spaced guide ways
- Wedge-style design

## [Counter spindle]

- Integrated, water-cooled spindle motor
- A2-6 spindle nose
- High drive power 29 kW
- High torque 250 Nm
- Large speed range 0 – 5000 rpm
- Incl. coolant-fed parts ejector
- Optional with Ø 65 mm through hole for shaft unloading

## [Chip conveyor]

- Hinged type conveyor belt
- Ejection height 1200 mm
- Integrated coolant tank 350 l
- Turret pumps: 3 x 14 bar
- Flushing pumps: 2 x 3.7 bar

## [Work area]

- Large spindle distance 1300 mm
- Optimum accessibility
- Straight chip drop
- Stainless steel covers and linings
- Tailstock/steady rest function on lower turret

## [Finished parts container]

- Easy access
- Universal
- Extendable with finished part conveyor

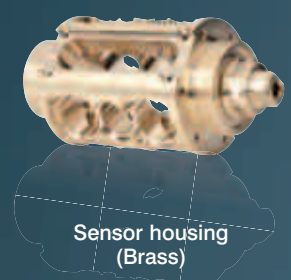

# [Engineering]

## Highlights

- Up to 30% more productivity for bar stock machining
- Increased flexibility through use of a 3rd tool turret
- Up to 48 milling tools for complete machining
- 3 independent Y-axes for unrestricted milling
- 2 integrated, water-cooled spindle motors (29 kW)
- Optimum chip flow and user-friendly work area
- Sinumerik 840D-sl for high-performance drive and controls
- Made in the Heart of Europe

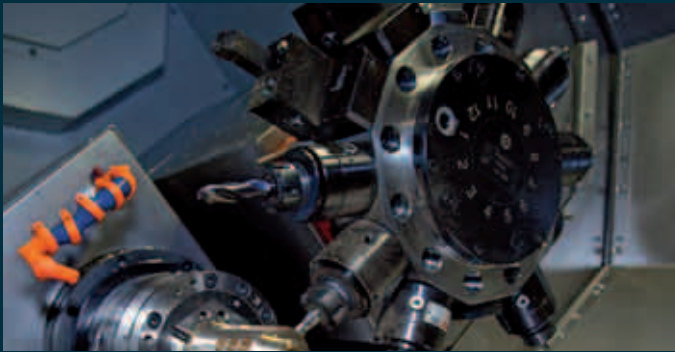

**Tool turret.** Fast 12-station servo turret with very short switching times for standardized VDI30 or VDI40 tools. All stations can hold driven tools for drilling, milling, and tapping. The operator is able to control the indexing speed with the override switch at any time.



**Parts catcher.** The HYPERTURN 65's pneumatic parts catcher is controlled using M functions. When needed, it traverses to the front of the work area and pivots to the spindle center. The finished part is removed from the clamping device and transferred to the catcher tray. The parts catcher then moves back to its initial position and the part is tipped into a catching box or onto a conveyor belt.

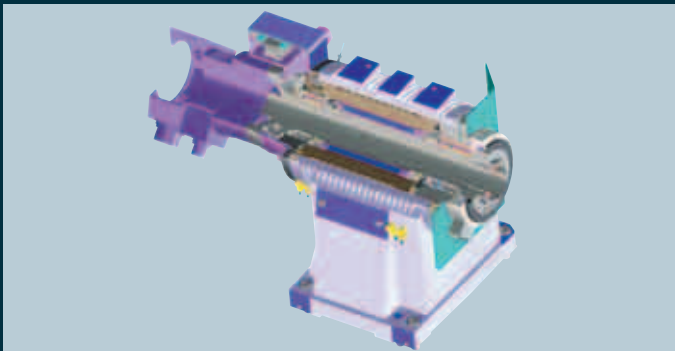

**Integrated spindle motor (ISM).** The latest synchronous technology guarantees the highest dynamics and exceptional torque in a compact design. Liquid cooling in conjunction with automatic temperature control maintains a constant temperature for all spindle motors.

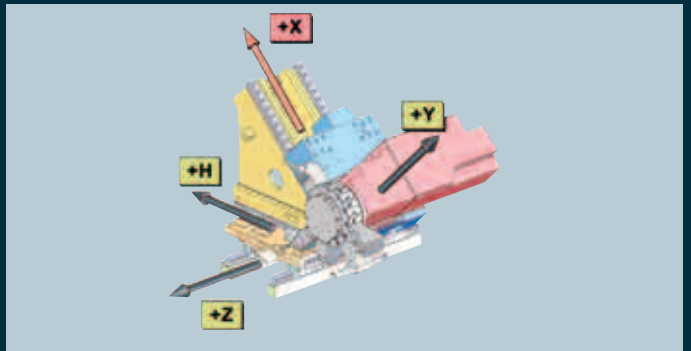

**High-precision Y-axis.** The HYPERTURN's Y-axis is designed to distribute the cutting forces over two guide planes. The result: outstanding rigidity for all turning and milling operations. The +/- 50 mm travel permits off-center milling and drilling.



**Storage tray.** The fold-out cover beneath the machine control unit provides an additional, convenient storage surface for measuring devices, tools, etc. The clamping pressure display with pressure reduction valves is also located directly on the front of the machine. The machine operator benefits from convenient access to the 220 V power socket, network connection, and air connector directly adjacent to the work area.



**Large workspace.** With 1300 mm spindle distance, the HYPERTURN 65-TT offers the largest workspace in its class. For users, this means maximum flexibility and the lowest possible risk of collision. As a result, even longer workpieces can be drilled and bored on the main and counter spindle simultaneously.

## Performance and torque diagram

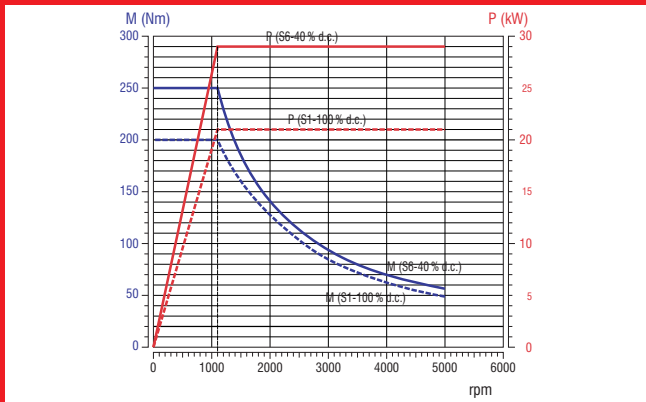

HYPERTURN 65 main and counter spindle

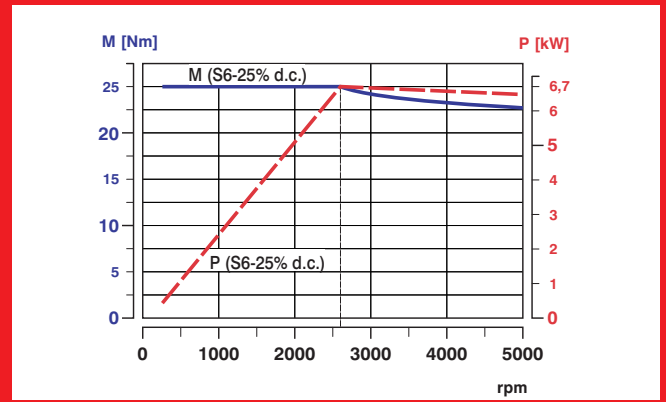

Tool turret - driven tools

## Machine layout HYPERTURN 65

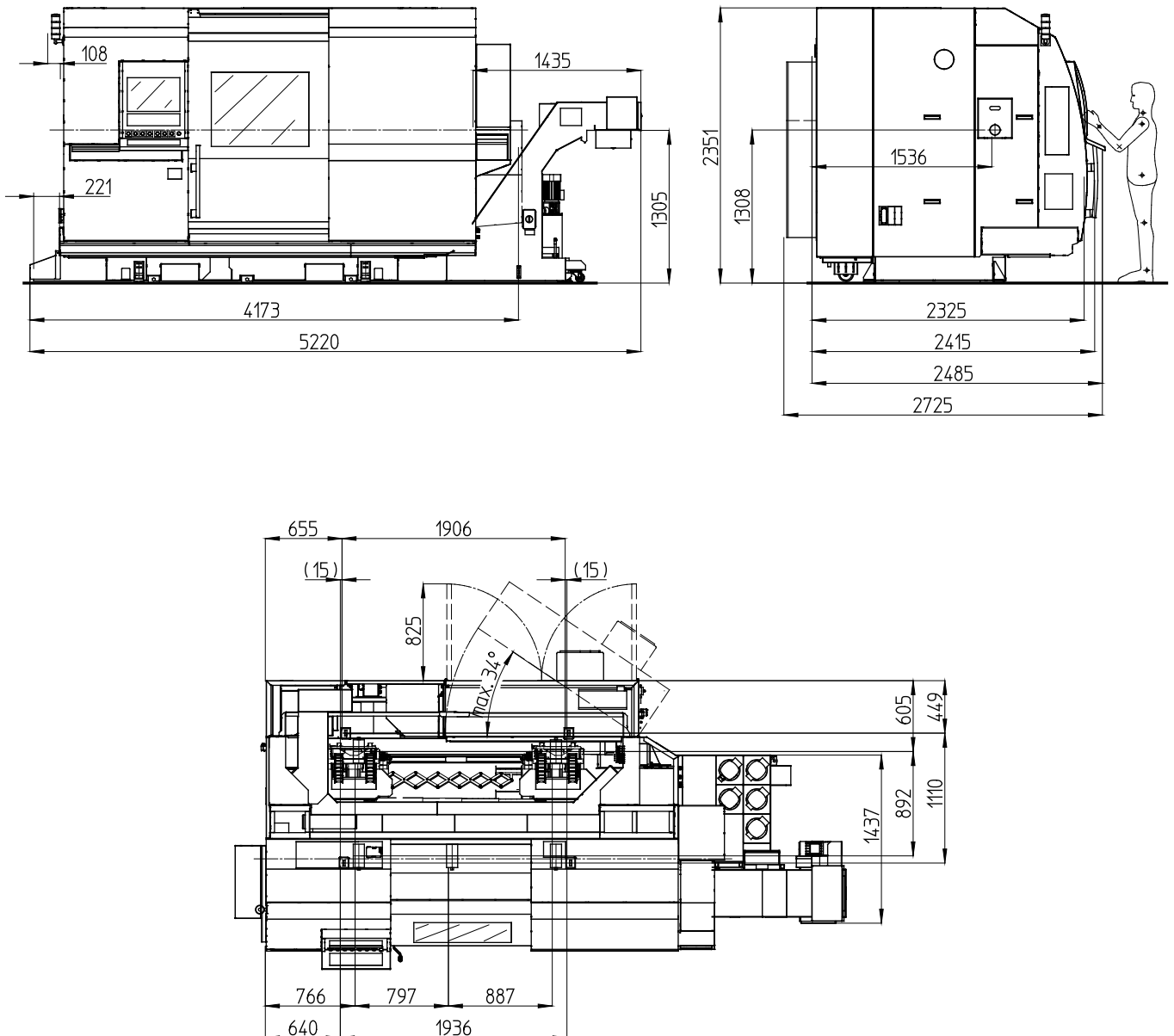

Indications in millimeters



# EMCO TOP LOAD.

## The premium class.

**Quality by the meter.** The EMCO TOP LOAD series was designed to automatically load 3-meter long bar stock into EMCO machines. Loaders are available for diameters of 4 - 25 mm, 8 - 42 mm, and 10 - 65 mm. The oil-coolant-fed loading channel, lined with plastic shells, reduces vibrations to a minimum, even at high speeds. Bar stock is fed in via a servo motor which controls both the speed and feed force. A patented guidance system with several guide rests guarantees optimum feed quality. Time-consuming conversions and channel changes are a thing of the past. The bar loader can be switched from one diameter to another within one or two minutes.

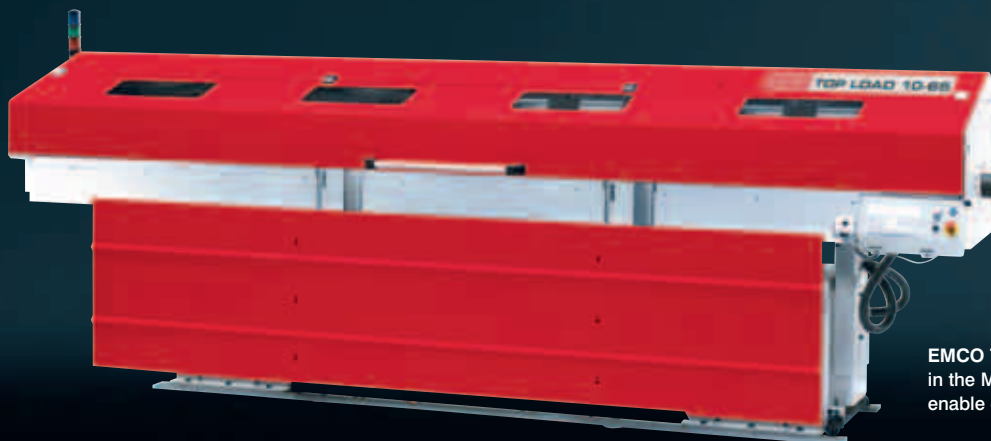

EMCO TOP LOAD 10-65/3300  
in the MULTI-LEVEL version. Multiple material supports  
enable even longer unmanned operation.

# The EMCO short bar loaders.

## Universal, high-performance.

**Short and to the point.** Faced by ever-increasing pressure on floorspace for machines, EMCO has developed the most compact short loaders on the market: The EMCO LM800 and EMCO LM1200/1500 are the perfect solution for automatic feeding and loading of cut-to-length bars. The key advantages are a small footprint and rapid loading times resulting from shorter strokes.

**The technology.** The loaders in our LM series can be used immediately as a „plug-and-play“ solution. Their extremely small footprint enables processes to be automated even if space is tight. In contrast to the EMCO COMPACT LOADS, the loaders in the LM series are fitted with their own control units, which also enables the loaders to be used together with other machines. The controls are perfectly coordinated with the machine interfaces, which are identical on all three models. All loaders offer comprehensive cycle support and are optimally aligned to the spindle lengths in the individual machines. Changing over to different bar diameters requires only minimum effort and the loaders can also be used to load individual workpieces.



EMCO LM1200  
Compatible with the machines EMCOTURN E65,  
MAXXTURN 65, HYPERTURN 45, HYPERTURN 665.



Infeed of profile bar stock using a chain feeding  
system (option)



# ESPRIT™

The Right Choice

The Esprit CAM system offers high flexibility and process security, a comprehensive selection of machining cycles, maximum tool control, and cross-machine technology for your entire production facility.



## [CAD]

Direct CAD data import

- AutoCAD (DWG)
- Parasolid®
- Solid Edge®
- Solid Works®
- ACIS® (SAT)
- Optional interfaces: CATIA®, Pro/ENGINEER®, STEP, STL,...

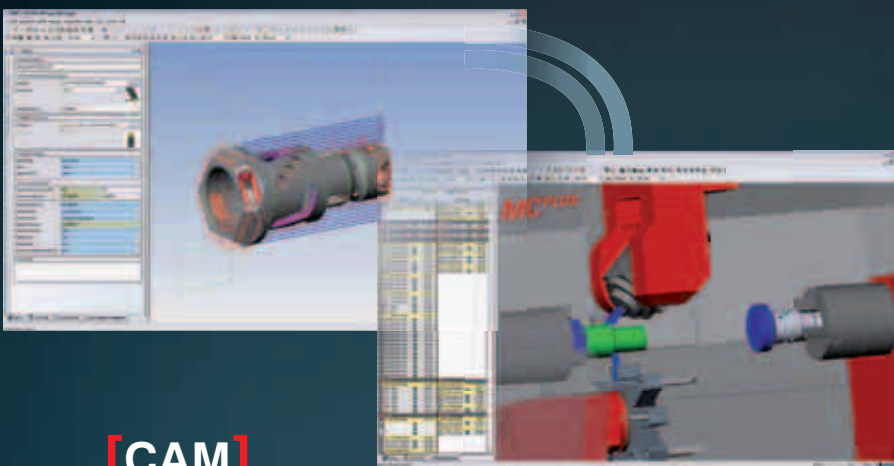

## [CAM]

- 2-22 axis turning
- 2-5 axis milling
- Multi-tasking of turning and milling
- 3D machine space simulation
- Certified post-processors

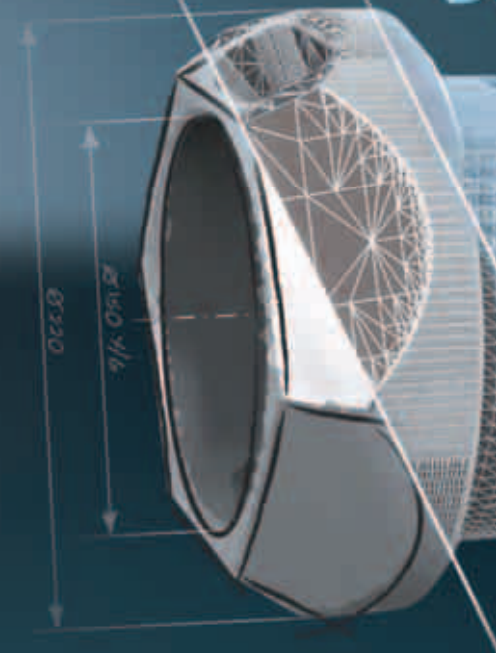
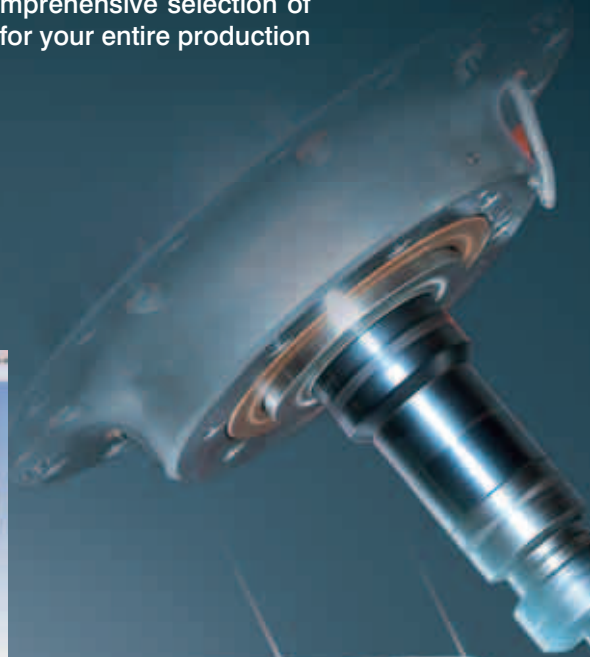

## [CAD]

# emco CPS | Pilot

## The Virtual Machine

A 1:1 mapping of the real machine for defining and testing processes, optimizing machining sequences, and training new operators.

### [Process chain]



### [CPS]

- 1:1 simulation with collision detection
- Direct connection to CAM ESPRIT
- Process optimization
- Reverse simulation of existing NC codes
- Reduction in scrap rates
- Training on the virtual machine
- Simulation of loading systems (e.g. EMCO gantry loader)

### [CAM]

### [CPS]

### [Production]

### [Production]

- Reduction in set-up costs
- Reduction in downtimes
- Reduction in repair costs

**OPTIMUM MACHINE UTILIZATION**

# Quality components



## [Machine bases and slides]

When matching components, we place great value on high stability, good damping characteristics, and a thermoneutral design. We achieve high stability through a shorter force flow, thermal stability through symmetry, and dampening through the materials and interfaces selected.



[www.emco-magdeburg.de](http://www.emco-magdeburg.de)

## [Headstocks]

The design and manufacture of headstocks are two of EMCO's core competencies. During engineering, the focus is on precision, robustness, high rigidity, precise rotational characteristics, and a long service life.



[www.emco-magdeburg.de](http://www.emco-magdeburg.de)

## [Tool turret]

Rapid-indexing turrets with adjustable swivel speeds and milling drives represent the current state of the art. The backlash-free milling drive is not only ideal for milling and drilling, but also for rigid tapping, hobbing, and polygonal turning.

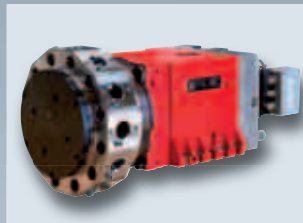

[www.sauter-feinmechanik.com](http://www.sauter-feinmechanik.com)

## [Tool holder]

Innovative, fully developed tool holder systems form the basis for cost-effective machining. High changeover accuracy and stability result in short setup and cycle times.

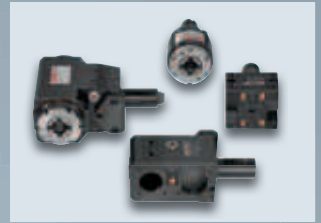

[www.wto.de](http://www.wto.de)

## [Clamping cylinder / chuck]

Hydraulically activated clamping cylinders and chucks guarantee the precise, safe clamping of work pieces. Programmable sensors are used for stroke monitoring. There is no need for time-consuming adjustments of contactless limit switches.



[www.roehm.biz](http://www.roehm.biz)

## [Hydraulic systems]

Compact dimensions, quiet operation, and high energy efficiency - just some of the advantages of the hydraulic assemblies used by EMCO. Monitored pressure switches prevent the need for time-consuming manual pressure adjustments.



[www.hawe.de](http://www.hawe.de)

## [Ball screws and roller guides]

Highly precise and generously dimensioned guide rails and ball screws with optimal pretensioning form the basis for the machining of precision parts.

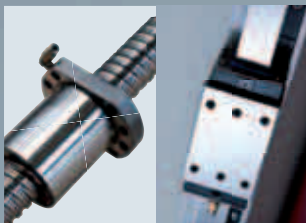

[www.boschrexroth.com](http://www.boschrexroth.com)

## [Chip conveyor]

Slat band conveyors allow for flexible implementation and the safe removal of chips. A monitored overload clutch prevents damage from improper use.

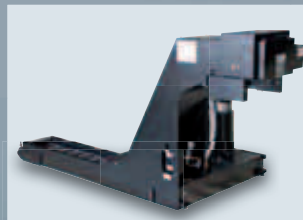

[www.knollmb.de](http://www.knollmb.de)

## [Coolant pumps]

Low-maintenance immersion pumps for pressures of up to 25 bar and flow rates of up to 1500 l/min provide optimum conditions for machining and enable reliable chip transportation.



[www.grundfos.at](http://www.grundfos.at)

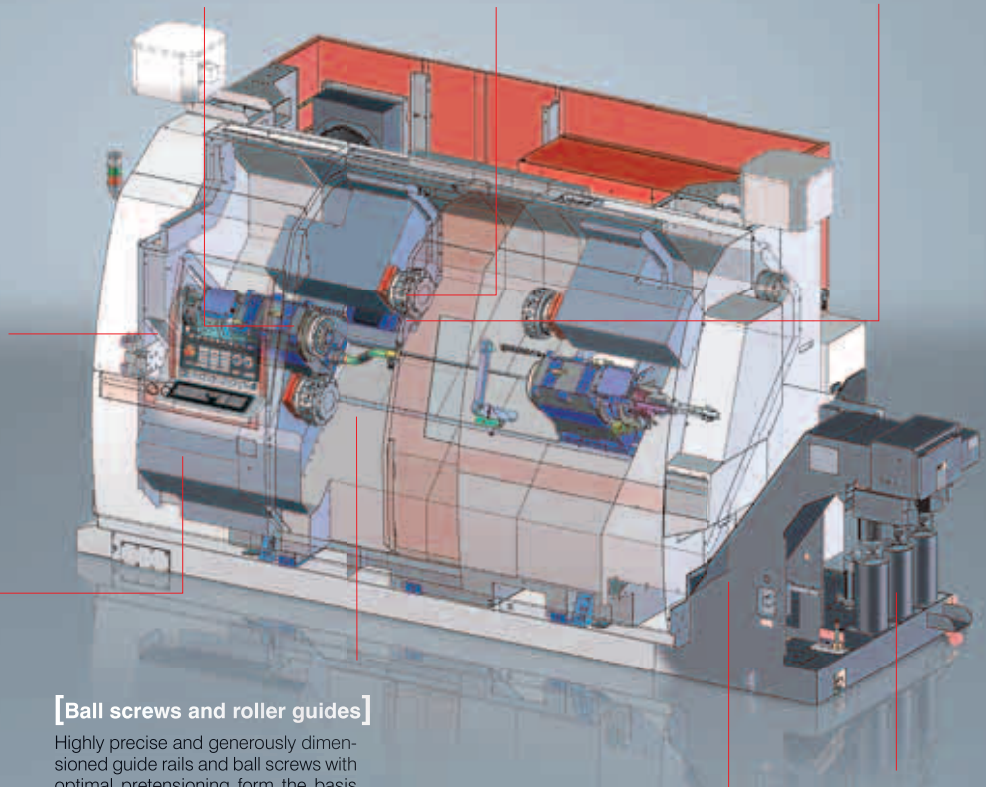

# Minimum use of resources for maximum profit.

**E[M]COLOGY**  
Designed for Efficiency

At EMCO, we take a consistent, responsible approach to the use of resources in machine tools in order to safeguard long-term investments. From the development of our machines through to their construction and manufacture, we place a strong focus on the sensible and sparing use of raw materials and energy. This enables us to achieve parallel savings in two areas:

1. Reduction in the basic power consumption of machine tools, e.g. assemblies are switched on and off as required and the installed connected loads are kept to a minimum.
2. Reduction in variable consumption: This can be seen in the lighter axes, energy recovery system, increased rate of good parts, and the shorter process chain enabled by complete machining.

Through these measures, which are constantly being refined and further optimized, EMCO truly demonstrates that its slogan of „Designed for your Profit“ is not just an empty promise: EMCO products help save the environment and provide intelligent customer savings without compromising on quality and flexibility.



**[Regenerative drive system]**  
Kinetic energy is converted into electrical energy and fed back into the grid.  
**Savings of up to 10%**



**[Compact hydraulics unit with pressure accumulator]**  
Thanks to its accumulator charging system, the pump only runs when required. If the pressure accumulator is full, the pump switches over to closed loop circulation.  
**Savings of up to 90%**



**[Roller guides]**  
Extremely low friction losses thanks to rolling friction. Highly dynamic performance with minimal lubricant consumption.  
**Savings of up to 50%**



**[Structurally optimized mechanics]**  
FEM analysis is used to optimize the relevant components in terms of their rigidity while simultaneously reducing their weight.  
**Savings of up to 10%**

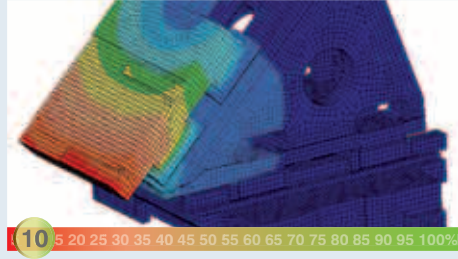

**[Highly efficient motors]**  
The use of energy-efficient motors (IE2) in the coolant preparation area guarantee highly cost-effective operation.  
**Savings of up to 10%**

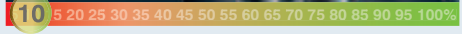

**[Synchronized chip conveyor]**  
Programmable interval times enable optimal use of the chip conveyor independently of the machining process.  
**Savings of up to 95%**

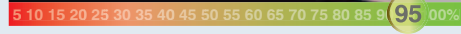
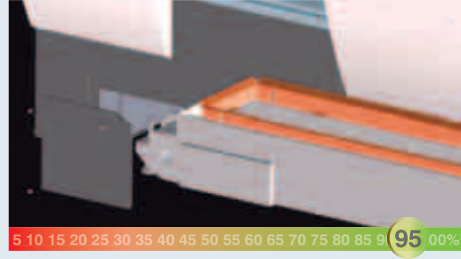

**[Intelligent standby concepts]**  
Reduced consumption by automatically switching off ancillary units and machine space/screen illumination after a defined period of inactivity on the control panel.  
**Savings of up to 50%**



**[Virtual machine]**  
Significant reduction in the setup and running-in times on the machine through the use of highly developed simulation and programming software.  
**Savings of up to 85%**

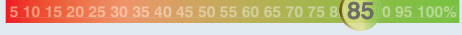

**[Intelligent energy management]**  
Intuitive data entry screens for activating the individual energy-saving functions.  
**Savings of up to 70%**

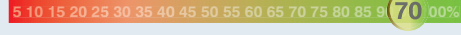

# [Technical Data]

**emco** group

Designed for your profit

## HYPERTURN 65

Work area	
Swing over bed	660 mm (25.0")
Swing over cross slide	540 mm (21.3")
Distance between spindle noses	1300 mm (51.2")
Maximum turning diameter	500 mm (19.7")
Max. part length	1000 mm (39.4")
Max. bar-stock diameter	65 (76.2) mm ((2.6") (3.0"))
Travel	
Traverse path X1 / X2 (HT65 DUOTURN)	260 / 210 mm (10.2 / 8.3")
Traverse path X1 / X2 / X3 (HT65 TRIPLETURN)	260 / 260 / 210 mm (10.2 / 10.2 / 8.3")
Traverse path Z1 / Z2 (HT65 DUOTURN)	1050 / 1050 mm (18.1 / 18.1")
Traverse path Z1 / Z2 / Z3 (HT65 TRIPLETURN)	460 / 460 / 1050 mm (18.1 / 18.1 / 41.3")
Traverse path Y1 / Y2 / Y3	100 (+ / -50) mm (3.9" (+ / -2.0"))
Main spindle	
Speed range (infinitely variable)	0 – 5000 rpm
Maximum torque	250 Nm (184.4 ft/lbs)
Spindle nose DIN 55026	A2-6 (A2-8)
Spindle bearing (inside diameter)	105 (130) mm (4.1" (5.1"))
Spindle bore (excluding draw-back rod)	73 (86) mm dia. (2.8" (3.4") dia.
Counter spindle	
Speed range (infinitely variable)	0 – 5000 rpm
Maximum torque	250 Nm (184.4ft/lbs)
Spindle nose DIN 55026	A2-6
Spindle bearing (inside diameter)	Ø 105 mm (4.1")
C-axes	
Resolution	0.001°
Rapid traverse	1000 rpm
Drive power	
Main spindle (AC integrated-spindle motor)	29 kW (38.9 hp)
Counter spindle (AC integrated-spindle motor)	29 kW (38.9 hp)

Tool turrets top and bottom	
Number of tool stations	3 x 12
VDI shaft (DIN 69880)	30 (40) mm (1.2" (1.6"))
Tool cross-section for square-shank tools	20 x 20 (25 x 25) mm (0.8 x 0.8" (1.0 x 1.0"))
Shank diameter for boring bars	32 mm (1.2")
Tool indexing time	0.7 sec
Driven tools	
Speed range	0 – 5000 (4500) rpm
Torque	25 Nm (18.4 ft/lbs)
Drive power	6.7 kW (9.0 hp)
Driven tools	3 x 12
Feed drives	
Rapid speed X1 / X2 / X3	30 m/min (1.2"/min)
Rapid speed Z1 / Z2 / Z3	30 m/min (1.2"/min)
Rapid speed Y1 / Y2 / Y3	12 m/min (0.5"/min)
Feed force X1 / X2 / X3	5000 N
Feed force Z1 / Z2 / Z3	8000 N
Coolant system	
Tank capacity	350 l (77 gal)
Pump capacity	3 x 2.2 kW (4.0 x 2.9 hp)
Power consumption	
Connected load	46 kVA
Compressed air	6 bar (87 PSI)
Dimensions	
Height of center above floor	1300 mm (51.2")
Overall height	2340 mm (92.1")
Required space L x D (without chip conveyor)	3950 x 2400 mm (155.5 x 94.5")
Total weight	approx. 9500 kg (20943.9 lb)
Safety devices	
	CE compliant



EN4351 · 02/12 · Technical modifications reserved. Errors and omissions excepted.

[www.emco-world.com](http://www.emco-world.com)