

[That's
E[M]CONOMY:]

emcogroup

Designed for your profit



Perfect fusion of resolution and dynamic.
FAMUP LINEARMILL 600

5 axes high-performance machining center

FAMUP LINEARMILL 600

[Tool turret]

- 40 tool stations
- Filling of the tool magazine through a separate loading door on the side of the machine

[Milling spindle]

- High drive power
- Compact, thermostable construction
- Wide speed range

[Work area]

- Free chip fall
- Optimal ergonomics
- 100 % covering of guide ways
- Optimum illumination



Machine fitted with optional equipment

The Linearmill 600 is the ideal solution for dynamic 5 axes machining of medium-sized parts. Highly dynamic linear drives ensure the rapid movement of the cutting tool. State-of-the-art torque motors move the swivelling rotary table powerfully and precisely during operation. Intelligent machine geometry and glass scales in all three axes as a standard fitting guarantee best stability and precision, even during the most difficult cutting jobs.

[Workpieces]

[Machine cover]

- All-round protection against flying chips
- 100 % coolant containment
- Large toughened-glass window in door
- Optimal view of the work area

[Control]

- State-of-the-art digital control technology
- LCD color screen
- Siemens 840D Solution Line or Heidenhain iTNC 530

[Titing rotary table]

- Driven by Torque motors
- For highly precise positioning and interpolation
- Clamping area: \varnothing 600 mm
- T-slots with dimension 14 mm H8 for standard clamps

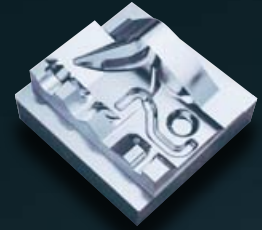

Mold part
(Brass)



Injection mold
(Brass)

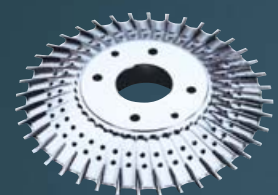

Measuring wheel
(Free cutting steel)

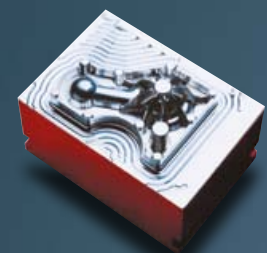

Injection mold
(Steel)

[Engineering]

Highlights

- Compact machine layout
- Very stable machine construction
- Linear drives in all three axes
- Integrated measuring systems in all three axes and on the tilting table
- Tilting table controlled by Torque motors
- Water-cooled motor spindle with 15000 rpm
- Controls Siemens 840D SL, Heidenhain iTNC 530
- Made in the Heart of Europe



Swivelling table. The swivelling table is controlled by state-of-the-art torque motors. This technology ensures highly precise positioning and interpolating throughout the entire life of the machine, as unlike worm gears, there can be no wear in this system. Reverse play and positioning hysteresis are completely eliminated. The water cooling system ensures constant temperatures, even with highly dynamic applications.



Linear drives. The 3 linear axes are powered directly by linear motors. This has some major advantages: top dynamics 7 m/s^2 (394''/s^2), high rapid motion speed 60 m/min (2362 ipm), fast and very precise radius transitions, precision down to $1.5 \text{ } \mu\text{m}$ (0.000059''), high contour accuracy as no backlash or hysteresis, high temperature consistency due to the water cooling system, no wear, life-long precision.

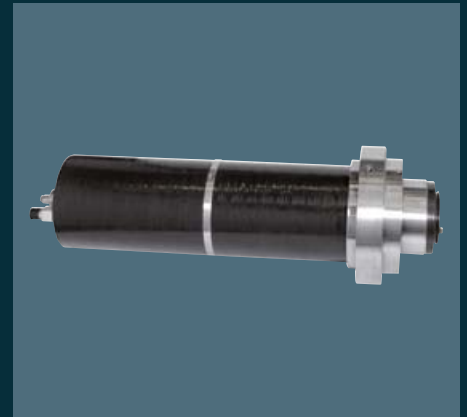

Motor spindle. The LINEARMILL 600 is equipped with a motor spindle. The performance data leave no doubt: 15000 rpm with liquid cooling. Top performance no less than 34.5 kW (46.3 hp) with a maximum torque of 110 Nm (81.2 ft/lbs).



Tilting rotary table. The $\text{Ø } 600 \text{ mm}$ (23.6'') clamping surface means many different medium-sized parts can be chucked. There are seven 14 mm (0.55'') H8 clamping grooves in the table for standard clamps. The center of the table is set up for connections for 2 hydraulic and 1 pneumatic line. Parts can also be clamped either hydraulically or pneumatically with the „rotary coupling“ option.



Tool loading. The tool magazine is filled through a separate loading door on the side of the machine. Tools can also be checked and exchanged during a machining cycle, without having to stop the machine. The magazine can hold 40 tools.

Performance

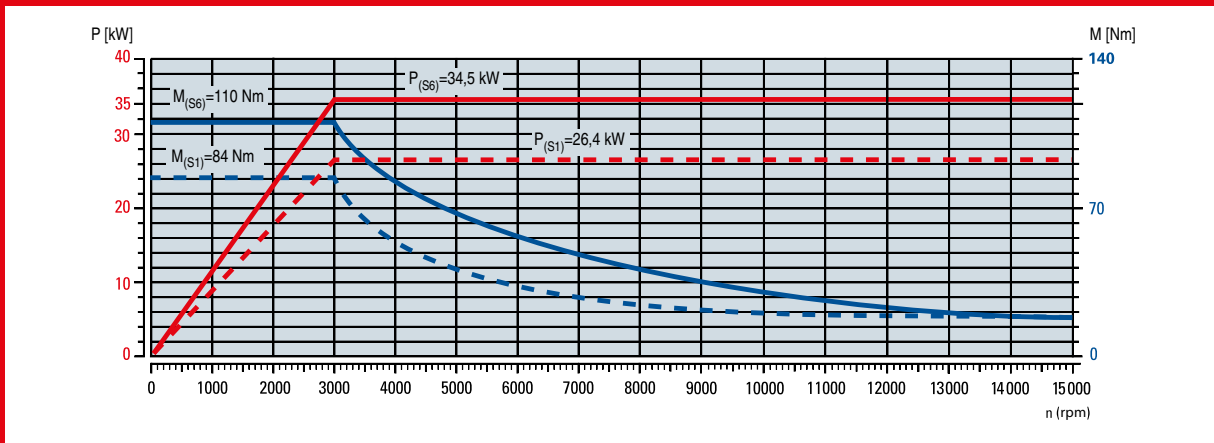

Intelligent machine construction. Stable machines are characterized by short distances between the tool and the next guide shoes. The unique carriage concept of the LINEARMILL 600 answers to this demand in a most impressive way: the highly stable box-shaped Z carriage transmits the cutting forces directly to the solid Y carriage. 6 sliding carriages lead the Y carriage on the flat cross-support. Robust guideways ensure the greatest possible shock absorption and precision for the entire life of the machine. The tool magazine is located directly on the working stroke, resulting in short chip-to-chip times. The machine stand is anchored to the floor with 7 shock absorbant levelling elements. The vertically mounted tilting bridge is joined very solidly to the 3 linear axes via the stand.

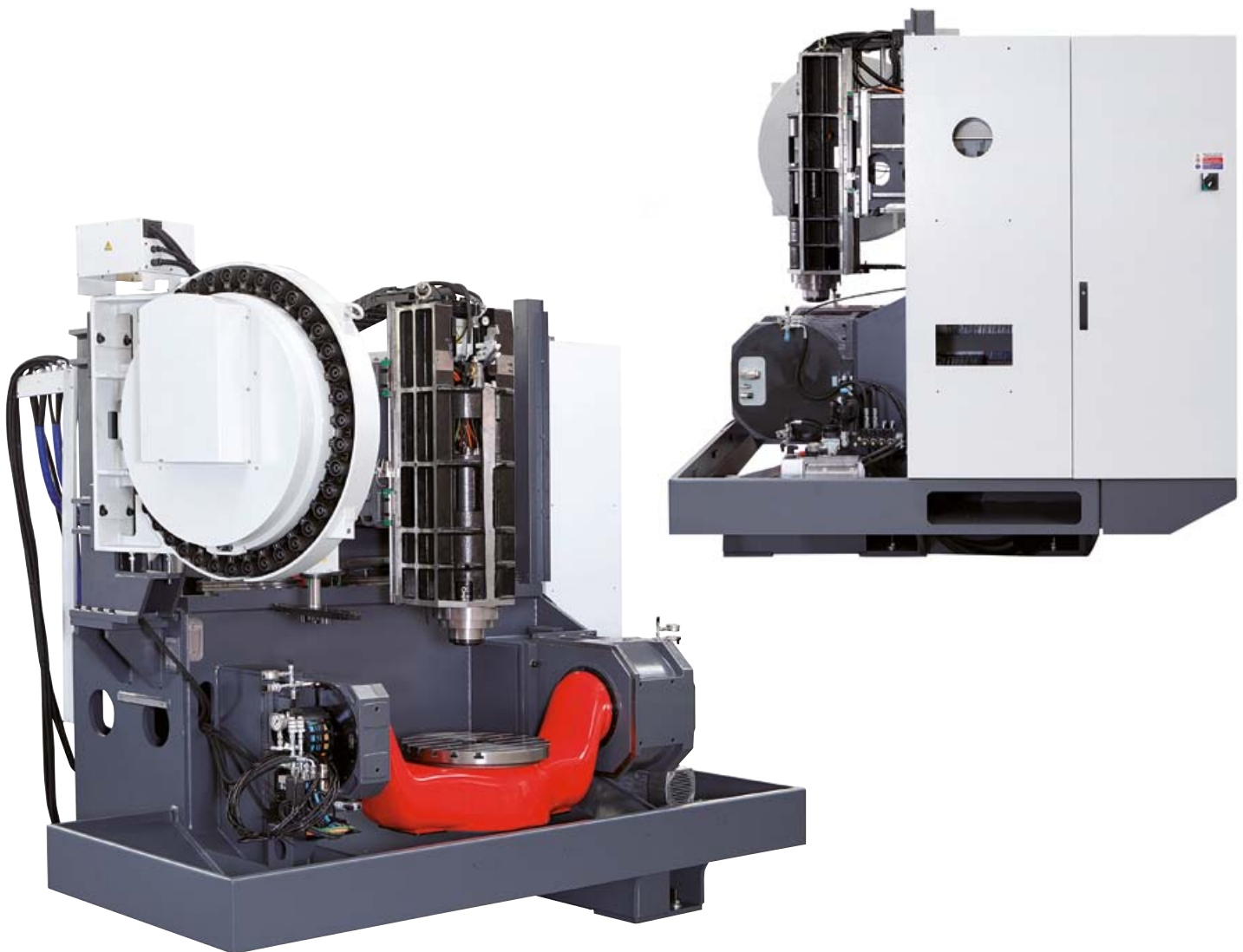

Machine construction. The machine is a typical travelling column machine. The X carriages with their cross supports are over a solid base. The Y carriages are guided via 6 guide shoes and kept extremely stiff. The Z movement is via the head, which is structured as a carriage with guides. Short distances from the spindle nose to the guide shoes ensure stable and low-vibration machining.

[Floor plans]

Machine layout

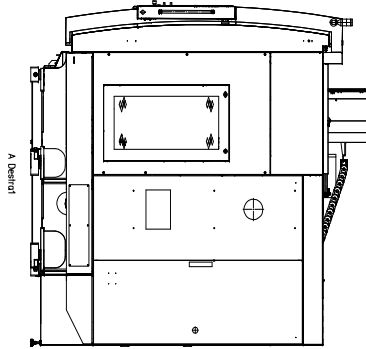
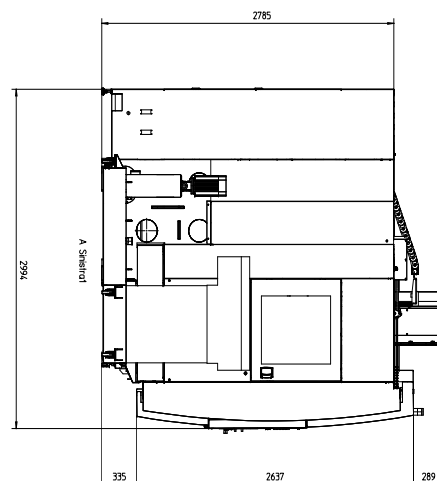
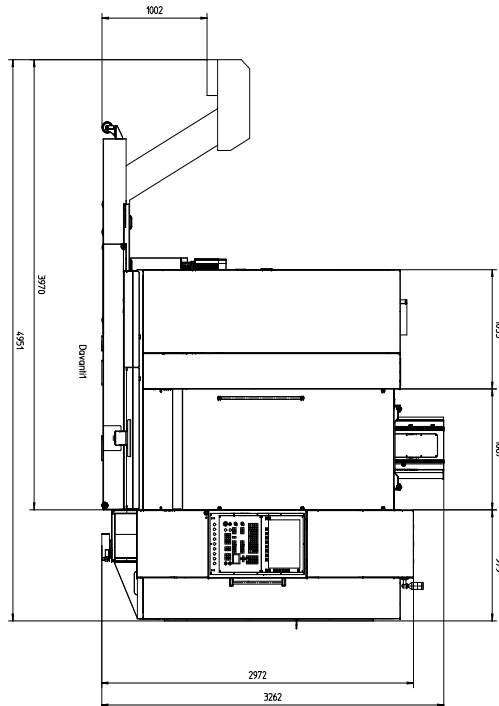
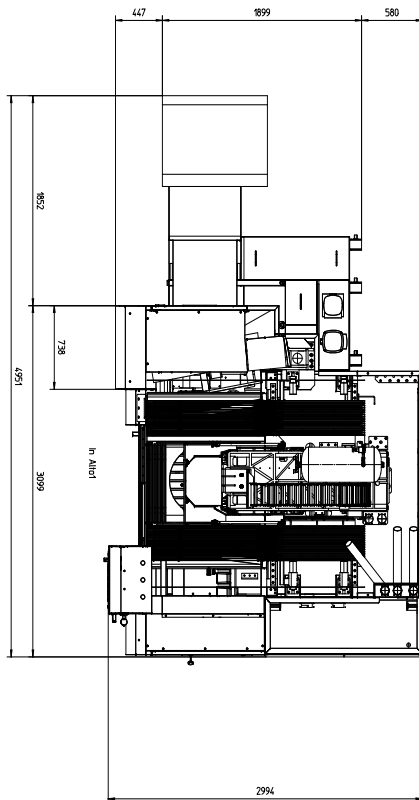

Indications in millimeters/inches

Work area

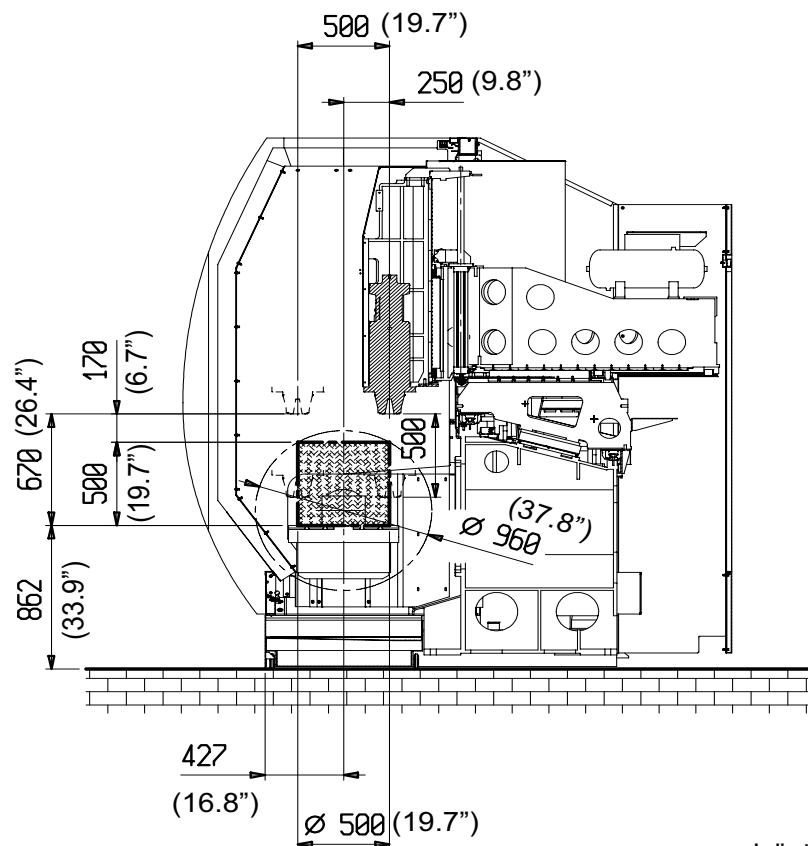
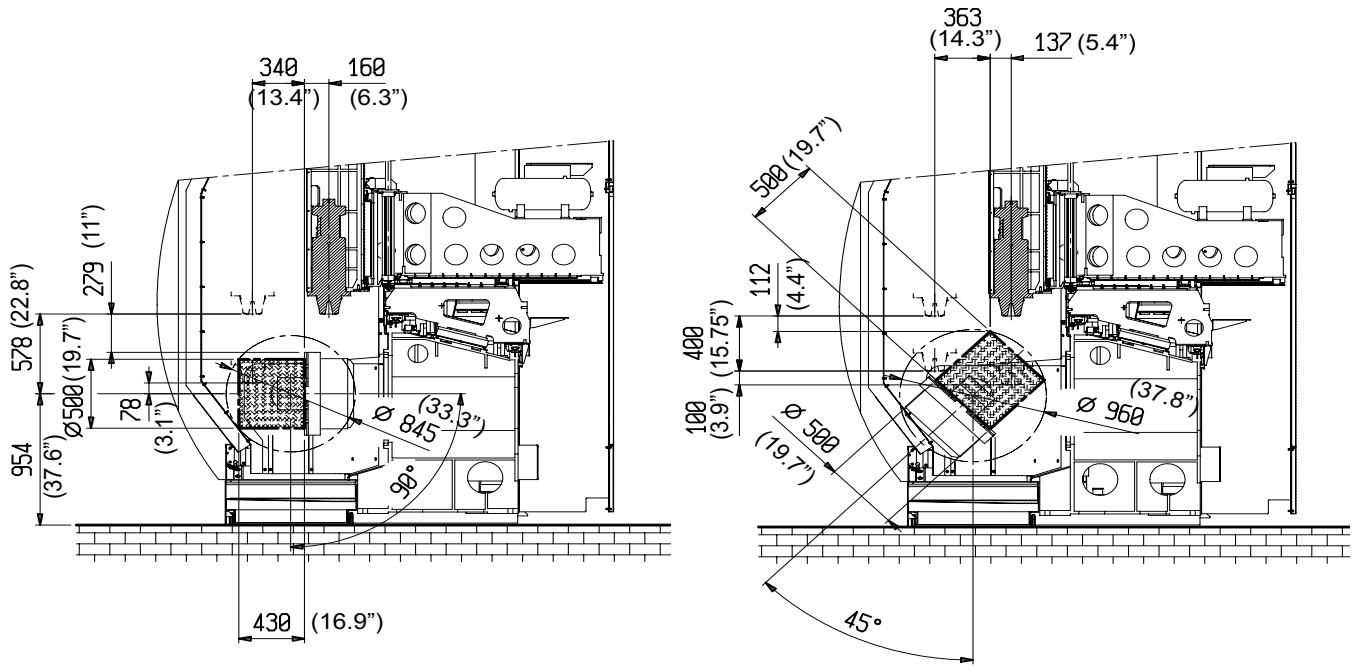

Indications in millimeters/inches

[Technical data]



Designed for your profit

FAMUP LINEARMILL 600

Work area	
Travel in X	600 mm (23.6")
Travel in Y	500 mm (19.7")
Travel in Z	500 mm (19.7")
Min./max. distance spindle nose–table	170 – 670 mm (6.7 – 26.4")
Axis data	
Rapid motion speed X, Y, Z	60 m/min (2362 ipm)
Axis acceleration X, Y, Z	7 m/s ² (280"/s ²)
One-sided positioning accuracy in entire stroke area	3 µm (0.00012")
One-sided repeating accuracy	1.5 µm (0.000059")
Spindle	
Max. spindle power (S6)	34.5 kW (46.3 hp)
Max. speed (S6)	110 Nm (81.2 ft/lbs)
Standard spindle speed	15000 rpm
Tool cone	HSK 63 A
Tilting table	
Table dimensions	Ø 600 mm (23.6")
Max. table load	800 kg (1764 lb)
Tilting range	+/- 120°

Tilting table	
Max. speed tilting axis	50 rpm
Max. speed table plate	100 rpm
Positioning precision of the pivoting axis	+/- 5"
Positioning precision of the table axis	+/- 5"
Tilting torque	1600 Nm (1179.2 ft/lbs)
Tilting torque max. acceleration (S6)	2125 Nm (1567 ft/lbs)
Table torque	615 Nm (453.6 ft/lbs)
Table torque max. acceleration (S6)	1100 Nm (810.7 ft/lbs)
Clamping torque of the tilting axis	5000 Nm (3685 ft/lbs)
Clamping torque of the table axis	2500 Nm (1842.5 ft/lbs)
Tool change	
Number of tool stations	40
Tool selection	random
Max. tool diameter (lateral empty positions)	80 / 125 mm (3.1 / 4.9")
Max. tool length	250 mm (9.8")
Max. tool weight	6 kg (13.2 lb)
Length of tool changer S-arm	600 mm (23.6")
Time for tool change (tool/tool)	1.7 sec



EN7141 - 05/13 - Subject to change due to technical progress. Errors and omissions excepted.

www.emco-world.com